



SERIE 823

823

822

INSTALLATION AND USE MANUAL



Made in Italy

AC 2711UK Rev. 06 - 10/14



TABLE OF CONTENTS

1.0 - PRELIMINARY ADVICE.....	PAGE
-------------------------------	------

USER MANUAL

2.0 - OPERATION.....	PAGE
2.1 - Complete system arming.....	PAGE
2.2 - System arming with sensor and comfort control exclusion.....	PAGE
2.3 - Passive arming.....	PAGE
2.4 - Arming inhibit time.....	PAGE
2.5 - System armed.....	PAGE
2.6 - Alarm, inhibit time between alarms and alarm cycles.....	PAGE
2.7 - System disarming.....	PAGE
2.8 - Emergency disarming by electronic key.....	PAGE
2.9 - Alarm memory.....	PAGE
3.0 - WARRANTY CONDITIONS.....	PAGE
4.0 - WASTE ELECTRICAL AND ELECTRONIC EQUIPMENT (WEEE) DIRECTIVE.....	PAGE

INSTALLER MANUAL

5.0 - PIN-OUT TABLES.....	PAGE
5.1 - 20-pin connector.....	PAGE
5.2 - 8-pin connector.....	PAGE
6.0 - COMPLETE ELECTRIC DIAGRAM.....	PAGE
7.0 - CONNECTIONS FOR ARMING VIA TURN INDICATORS.....	PAGE
7.1 - Standard connections.....	PAGE
7.2 - Connections for vehicles with separate lines.....	PAGE
7.3 - Connections to Hazard switch.....	PAGE
8.0 - CENTRAL LOCKING CONNECTIONS TO ARM/DISARM THE SYSTEM.....	PAGE
8.1 - Connections to actuators with separate radio receiver.....	PAGE
8.2 - Connections to actuators with lock switches.....	PAGE
8.3 - Connections to turn indicators.....	PAGE
9.0 - SELF-LEARNING OF TURN INDICATOR FLASHES.....	PAGE
10.0 - SYSTEM PROGRAMMING.....	PAGE
10.1 - Visual signalling.....	PAGE
10.2 - Audio signalling.....	PAGE
10.3 - Passive arming.....	PAGE
10.4 - Arming of siren (art. 7725) output.....	PAGE
10.5 - Boot switch polarity selection.....	PAGE
10.6 - Optical pulse signal/self-powered siren.....	PAGE
10.7 - Negative output selection (during alarm) for horn or additional siren.....	PAGE
11.0 - SYSTEM PROGRAMMING EXAMPLE.....	PAGE
12.0 - DIP-SWITCHES PROGRAMMING TABLE.....	PAGE
13.0 - ULTRASONIC VOLUMETRIC PROTECTION.....	PAGE
13.1 - Connections and positioning.....	PAGE
13.2 - Sensor adjustment.....	PAGE
14.0 - ADDING NEW DEVICES.....	PAGE
15.0 - DELETING PROGRAMMED DEVICES.....	PAGE
16.0 - SYSTEM RESET.....	PAGE
17.0 - TECHNICAL SPECIFICATIONS.....	PAGE

1.0 - PRELIMINARY ADVICE

Dear Customer, the present manual illustrates the top version of the alarm system; not all functions, electrical connections etc. will therefore apply to all models.

Before installing, identify your alarm model and refer to it for the correct instructions.

GEMINI 822: same as 823 without self-powered battery.

The following signs, intended for the installer or the user, indicate particular functions or connections as follows:



For the user.

This sign highlights useful information.



For the installer.

This sign indicates that the functioning of the alarm can vary according to connections and programming of the system or it simply provides useful indications for the installation.

USER MANUAL

2.0 - OPERATION

2.1 - COMPLETE SYSTEM ARMING

Press the lock button on the original remote control of the vehicle.

System arming is confirmed by a siren chirp (if feature status has been modified) and a flash of the turn indicators.

The system has a 30" pre-arming "neutral time" (indicated by the LED turned ON steady).

2.2 - SYSTEM ARMING WITH SENSOR AND COMFORT CONTROL EXCLUSION

This function allows arming the system while excluding internal volumetric protection, external sensors (infrared wireless) and comfort feature.

To activate this function, the system should be disarmed and the ignition key turned to the "OFF" position; proceed as follows.

- With doors opened: insert the electronic key into its receptacle, close vehicle doors and press the lock button on the original remote control.
- In both cases the system will be armed but only in the second case will the vehicle be also locked.



Sensors and comfort function exclusion is bound to each single arming cycle.

2.3 - PASSIVE ARMING

If this function is programmed, the system passively arms approx. 60" after switching ignition OFF and after opening and closing the last door.

System activation will be confirmed by the regular optical/acoustic arming signal.



In case of passive arming, internal sensors and comfort output (automatic window roll-up) will be excluded.

Opening a door 60" before the system is armed temporarily interrupts the procedure which will resume once the door is closed.

2.4 - ARMING INHIBIT TIME

The inhibit arming time lasts approximately 30" and is indicated by the LED turned ON; it is possible to exit the vehicle without triggering any alarm.

2.5 - SYSTEM ARMED

After the inhibit time the system is "armed" and ready to detect any theft attempt. When the system is fully armed, the LED flashes.

2.6 - ALARM, INHIBIT TIME BETWEEN ALARMS AND ALARM CYCLES

The system will indicate theft attempts by optical/acoustic signals.

After an alarm is triggered, but before another alarm cycle starts, there is a 5 sec. "neutral time".

An alarm event can generate up to 10 alarm cycles of 30" each for each input and for each arming cycle.

2.7 - SYSTEM DISARMING

Press the unlock button on the vehicle original remote control.

Disarming is confirmed by 2 siren chirps (if feature status has been modified) and 2 flashes of the turn indicators.

An alarm condition is signalled by 5 acoustic signals (if feature status has been modified) and 5 flashes of the turn indicators.

The various alarm causes and relative LED signals are detailed in paragraph (2.9).

2.8 - EMERGENCY DISARMING BY ELECTRONIC KEY

This disarming mode is used for "EMERGENCY DISARMING" and "TOTAL DISARMING".

Touching the electronic key to its receptacle disarms and switches off the system which will not rearm if the remote control is used.



To restore normal operation, touch the electronic key to its receptacle.
A quick chirp and a flash of the status LED will confirm that the system is back to normal mode.

2.9 - ALARM MEMORY

Five flashes of the turn indicators and five beeps (siren chirps, if feature status has been modified) upon disarming warn that the alarm has been triggered in your absence.

To identify the last cause of alarm, turn ignition ON and count the number of flashes of the status LED.

Optical signals are repeated 3 times in a row; to interrupt, turn ignition key "OFF".

The table below lists the various alarm causes and relative number of LED flashes.

LED FLASHES	ALARM CAUSES	ALARM CYCLES
* * ● * *	Ignition attempt (+15/54)	10
* * * ● * * *	Door opening	10
* * * * ● * * * *	Bonnet opening	10
* * * * * ● * * * * *	Boot opening	10
* * * * * * ● * * * * * *	Volumetric or external sensor	10
* * * * * * * * ● * * * * * * * *	Wire tampering	10
● LED OFF (2 seconds) * LED ON (1 second)		

3.0 - WARRANTY CONDITIONS

This product is guaranteed to be free from manufacturing defects for a period of 24 months from the installation date shown on this warranty, in compliance with the Directive 1999/44/CE.

Please fill-in entirely the guarantee certificate included in this booklet and do NOT REMOVE the guarantee label from the device.

The warranty will become void if labels are missing or torn, if the installation certificate is not fully compiled or if the enclosed sale document is missing.

The guarantee is valid exclusively at authorized Gemini Technologies S.p.A. Service Centers.

The manufacturer declines any responsibility for eventual malfunctions of the device or any damage to the vehicle electrical system due to improper installation, use or tampering.

This alarm system is solely intended to be a theft-deterrent device.

4.0 - WASTE ELECTRICAL AND ELECTRONIC EQUIPMENT (WEEE) DIRECTIVE

The present device does not fall within the scope of Directive 2002/96/EC on Waste Electrical and Electronic Equipment (WEEE) as specified in art. 2.1 of L.D. no. 151 of 25/07/2005.

INSTALLER MANUAL

5.0 - PINOUT TABLES

5.1 - 20-PIN CONNECTOR

POSITION	WIRE FUNCTION	WIRE COLOUR
- 1 -	Negative Input - door lock switch signal	YELLOW-RED
- 2 -	Arming signal	YELLOW-BLUE
- 3 -	Disarming signal	GREEN-BLUE
- 4 -	Positive/negative input - boot switch	GREEN-WHITE
- 5 -	Negative input - door switches	GREEN-BROWN
- 6 -	Input - electronic key receptacle	GREEN
- 7 -	Ground - receptacle for electronic key	BROWN
- 8 -	LED negative output	BLACK
- 9 -	LED positive output	RED
- 10 -	Ignition	BLACK marked "G"
- 11 -	Positive input - door lock switch signal	RED-BROWN
- 12 -	Programmable input - door lock switch signal	WHITE-LIGHT BLUE
- 13 -	Positive output with system armed (+A)	PINK
- 14 -	Negative input - external sensors	GREEN-BLACK
- 15 -	Negative input - bonnet switch	GREEN
- 16 -	Output - self-powered siren (lack of negative during alarm) or impulse visual signalling	BLUE
- 17 -	Comfort negative output	WHITE-BLACK
- 18 -	Negative output - additional siren or horn	YELLOW-BLACK
- 19 -	Antenna	BLACK
- 20 -	Learn input and system arm/disarm via turn indicators	WHITE-ORANGE



WHITE-ORANGE wires must ALWAYS be connected if system is to operate via the turn indicators.

5.2 - 8-PIN CONNECTOR

POSITION	WIRE FUNCTION	WIRE COLOUR
- 1 -	Ground	BLACK marked "M"
- 2 -	Siren output	----
- 3 -	Positive	BLACK marked "R"
- 4 -	Turn indicators positive output	ORANGE
- 5 -	Engine lock	BLACK marked "H"
- 6 -	Siren output	----
- 7 -	Engine lock	BLACK marked "H"
- 8 -	Turn indicators positive output	ORANGE

6.0 - COMPLETE ELECTRIC DIAGRAM

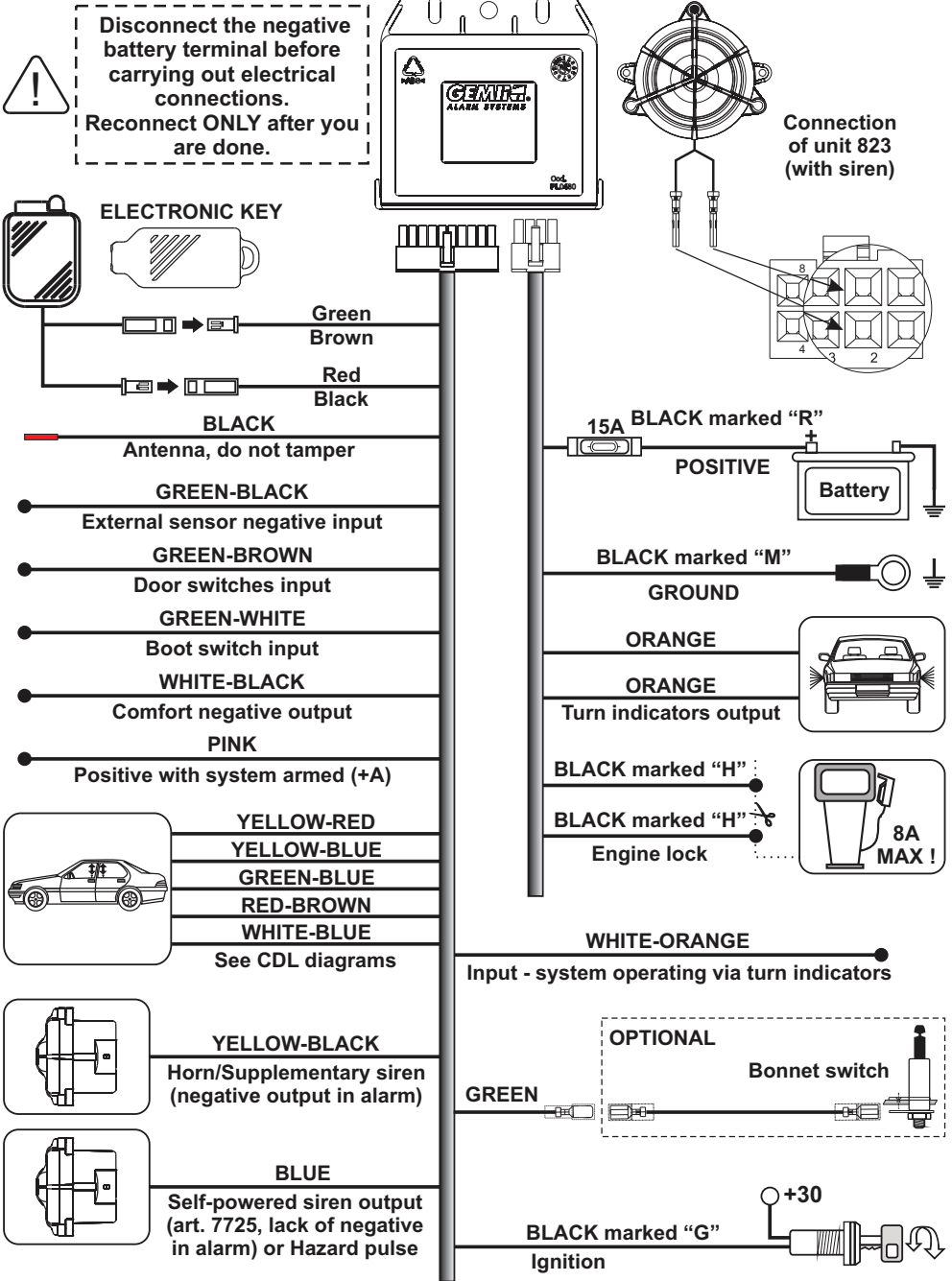

7.0 - CONNECTIONS FOR ARMING VIA TURN INDICATORS

7.1 - STANDARD CONNECTION

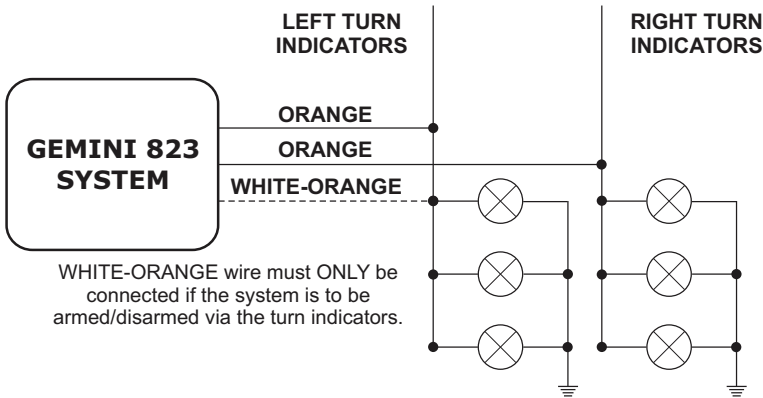

7.2 - CONNECTIONS FOR VEHICLES WITH SEPARATE LINES

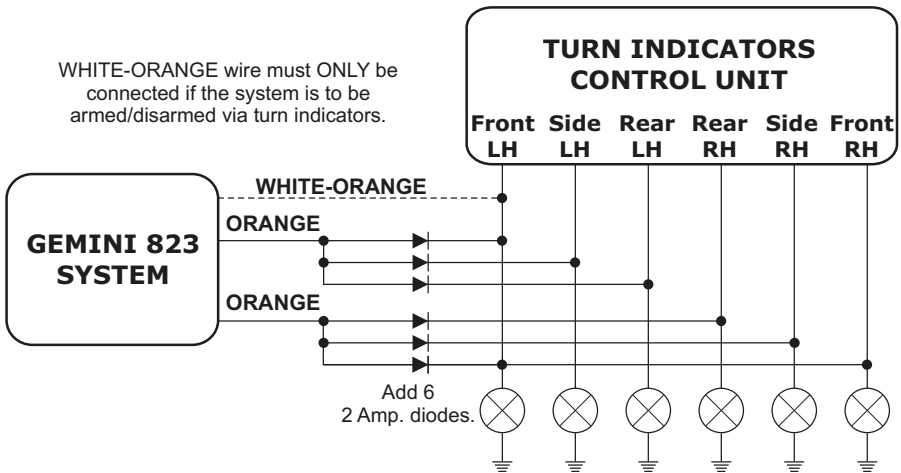

7.3 - CONNECTION TO HAZARD SWITCH

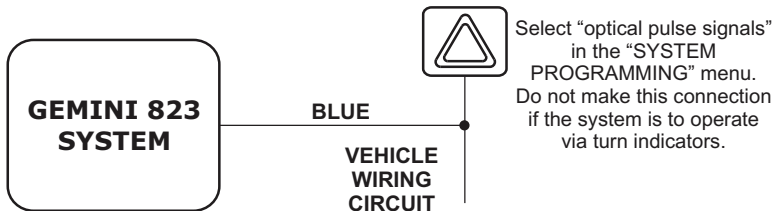

8.0 - CENTRAL LOCKING CONNECTIONS TO ARM/DISARM THE SYSTEM

Central door locking must be connected according to vehicle type (see installation schemes). Check out the various possibilities described below and proceed with the applicable connection.

- Arming via the lock actuators.
- Arming via the lock actuators and the lock/unlock switches.
- Arming via the turn indicator flashes.
- Arming via the turn indicator flashes and the lock actuators.
- Arming via the turn indicators flashes, the actuators and the lock/unlock switches.

8.1 - CONNECTIONS TO ACTUATORS WITH A SEPARATE RADIO RECEIVER

Arm/disarm connections for vehicles with a radio receiver that is separate from CDL (see www.gemini-alarm.com for diagram "A" connection).

Set dip-switch nr. 4 "ON".

8.2 - CONNECTIONS TO ACTUATORS WITH LOCK SWITCHES

Arming/disarming connections for vehicles that require connections to actuators but also require control of lock switches or internal lock/unlock switches (see www.gemini-alarm.com for diagram "C", "D", "E" connection).

Set dip-switch N. 4 "ON".

8.3 - CONNECTIONS TO TURN INDICATORS



If the turn indicators lock/unlock flashes are identical, connect the actuators.
If the turn indicators flash when unlocking via the car mechanical key, do not make this connection.

The arm/disarm connection is made by connecting the WHITE-ORANGE wire to the turn indicators.

If the arm/disarm connection is only via the turn indicators, set dip-switch N. 4 "OFF".

If the arm/disarm connection is via the turn indicators and the actuators, set dip-switch N. 4 "ON".

9.0 - SELF-LEARNING OF TURN INDICATOR FLASHES

In order to arm/disarm via the turn indicators, the system must learn the vehicle lock (arming) and unlock (disarming) flashes.

Connect the WHITE-ORANGE wire to the turn indicators and proceed as follows:

- Disconnect the 8-pin harness connector from the 8-pin alarm connector.
- Turn ignition key "ON".
- Connect the 8-pin harness connector to the 8-pin alarm connector; the LED will turn ON steady.
- Turn ignition key "OFF", close all doors and press the lock button on the original remote control.
- When the turn indicators stop flashing, a high-pitched acoustic signal confirms the learning of the arming flashes.
- Press the unlock button on the original remote control.
- When the turn indicators stop flashing, 2 high-pitched audio signals confirm the learning of the disarming flashes.
- This completes the procedure.

10.0 - SYSTEM PROGRAMMING

The table below applies to the system programmed in “standard configuration”. Every time you enter the programming procedure, the alarm resets to the default settings.

FUNCTION	STATUS	LED FLASHES
Exclusion of arm/disarm optic signals	Disabled	*
Exclusion of arm/disarm acoustic signals	Enabled	**
System passive arming	Disabled	***
Arming of self-powered coded siren	Disabled	****
Boot input, positive signal	Disabled	*****
Optical pulse signalling	Disabled	*****
Pulse negative output during alarm cycle	Disabled	*****

A lack of power during electrical system maintenance will not affect the programming. The procedure must be carried out entirely. To scroll from one function to another either turn the key to disable it or use the electronic key to enable the function (see par. 11.0).

Programmable functions are briefly described below.

10.1 - OPTICAL SIGNALS

This function activates optical signals when the system is armed and disarmed.



If the vehicle already has optical lock/unlock signals, the turn indicators alarm flashes should be deactivated.

10.2 - ACOUSTIC SIGNALS

This function activates acoustic signals when the system is armed and disarmed.

10.3 - PASSIVE ARMING

This function arms the system 60” after ignition is switched off and the last door is opened and closed. If a door is opened during this lapse of time, the procedure is interrupted; it will resume when the door is closed.

10.4 - ENABLING OF SIREN (7725) OUTPUT

This function enables the relative output (20-pin connector, position 13, PINK wire) to activate the self-powered coded siren (art. 7725).

10.5 - BOOT SWITCH POLARITY SELECTION

This function modifies the alarm input signal (positive or negative) according to the signal generated by the boot switch.

10.6 - OPTICAL PULSE SIGNAL/SELF-POWERED SIREN

This function activates the optical signals according to the connection made; only for vehicles where the hook-up is to the “emergency” switch wire (Hazard button).



When the optical pulse signaling feature is activated, the blinkers will ONLY emit optical signals during an alarm cycle.

The system BLUE wire MUST be connected to the Hazard button. In this case, do not connect the ORANGE wires (see chapter 7.3).

If the function is disabled, under normal operating conditions, the blue wire carries a negative signal; during an alarm cycle, there is a lack of negative.

10.7 - NEGATIVE OUTPUT SELECTION (DURING ALARM) FOR HORNS OR ADDITIONAL SIREN

Depending on the connection made, this function can activate the output for the siren (continuous tone) or for the horn (intermittent tone).

11.0 - SYSTEM PROGRAMMING EXAMPLE

The following example illustrates the steps to follow to modify the programmable functions. As mentioned before, turning the key OFF/ON disables the function, while using the electronic key enables it. To confirm the operation, a high or low pitched signal will sound and the LED will flash as indicated (see table, chapter 10.0).

With alarm system disarmed, turn ignition key "ON".



The LED will light up for about 2 seconds; during this period touch the electronic key to its receptacle.



Two acoustic signals (a high and a low-pitched beep) and 2 flashes of the turn indicators will confirm that the system has entered in programming mode.



Turn ignition "OFF" and then back "ON" to disable the function.
A low-pitched acoustic signal will confirm the operation.
The LED will flash according to the selected function (from 1 to 7).



OR



To enable the function, touch the electronic key once to its receptacle.
A high-pitched acoustic signal will confirm the operation.
The LED will flash according to the selected function (from 1 to 7).



In both cases, the system moves on to the next function. Repeat steps above to enable or disable all the other functions.

When the last function is configured (either with the electronic key or the ignition key), in addition to the confirmation tone, the system gives 2 low-pitched and 1 high-pitched acoustic signals and the turn indicators flash twice to confirm the end of the programming procedure.

12.0 - DIP-SWITCHES PROGRAMMING TABLE



Set dip-switches BEFORE connecting the alarm system.
If settings must be modified after installation, FIRST disconnect the alarm and then reset the dip-switches.

Nr.	POSITION	FUNCTION
1	ON	POSITIVE polarity for control on WHITE/LIGHT BLUE wire
1	OFF	NEGATIVE polarity for control on WHITE/LIGHT BLUE wire
2	ON	Positive signal (+A) on BROWN/RED with alarm ON
2	OFF	Standard operation
3	ON	Negative output to arm/disarm the system
3	OFF	Positive output to arm/disarm the system
4	ON	Arming/disarming via actuators or via actuators and turn indicators (See par. 8.0)
4	OFF	Arming/disarming only via turn indicators



With dip-switch N.2 set to "ON", the YELLOW-RED wire is grounded when the system is armed. Leave dip-switch in this position when connecting only the WHITE-LIGHT BLUE wire to the lock switch (grounded), with vehicle closed.

13.0 - ULTRASONIC VOLUMETRIC PROTECTION

13.1 - CONNECTIONS AND POSITIONING

Insert the WHITE connector in the the "W" socket on the control unit.

Insert the RED connector in the "R" socket on the control unit.

Install the ultrasonic sensors on the top part of the windshield internal pillars, away from the air vents and point them towards the center of the rear window.

13.2 - SENSOR ADJUSTMENT

To check sensor sensitivity level proceed as follows:

- With the alarm system disarmed, roll down the front window approx. 20 cm.
- Set the trimmer to an intermediate position (medium sensitivity).
- Close all doors, bonnet and boot and arm the system.
- During the pre-arming delay time, introduce an object in the cabin through the window and move it around; the status LED will turn off to signal a presence.
- If the sensity level is too high or too low, readjust the trimmer and repeat the above procedure.

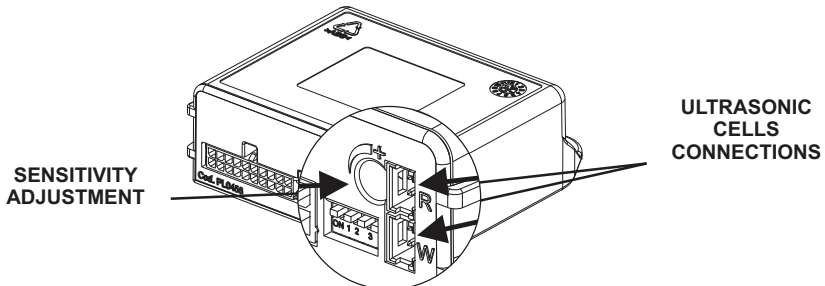

14.0 - ADDING NEW DEVICES



To carry out the operation successfully, make sure the required electrical connections (door/bonnet switches and ignition) are complete.



Storing memory is for 55 devices.
If an extra device is added, it will automatically delete the first device programmed in the system memory.

To activate the procedure proceed as follows:

- With the system disarmed, open the driver door and the bonnet and leave them open.



The following operations must be carried out within 4 seconds otherwise the procedure is invalidated.

- Turn ignition key "ON-OFF"-**"ON-OFF"**-**"ON-OFF"**-**"ON"**.
- At the fourth turn, leave it **"ON"**.
- To confirm it has entered in learning mode, the system gives 2 acoustic signals (one high and one low-pitched), the turn indicators flash once and the status LED turns ON.



Do not close the bonnet otherwise all previously programmed devices will be erased as described in the next paragraph.

- The system is ready to receive the device codes.
- Insert the electronic key into its receptacle.
- Each time a device is learned a high-pitched signal sounds and the status LED turns OFF briefly.
- Repeat this procedure to program other devices.
- Turn ignition key **"OFF"**.
- To confirm the end of the procedure, a low-pitched signal sounds, the turn indicators flash once and the status LED turns OFF.

15.0 - DELETING PROGRAMMED DEVICES



To carry out the operation successfully, make sure the required electrical connections (door/bonnet switches and ignition) are complete.

Any previously programmed device can be erased as follows.

- With the system disarmed, open the driver door and the bonnet and leave them open.



The following operations must be carried out within 4 seconds otherwise the procedure is invalidated.

- Turn ignition key “ON-OFF”-“ON-OFF”-“ON-OFF”-“ON”.
- At the fourth turn, leave it “ON”.
- To confirm it has entered in delete mode, the system gives 2 acoustic signals (one high and one low-pitched sound), the turn indicators flash once and the status LED turns ON.
- Close the bonnet.
- Keep the bonnet closed (approx. 8 sec.) until the devices are completely deleted.



If the bonnet is opened before 8 seconds, the devices will not be deleted.

- The status LED turns OFF when the devices have been deleted.
- Turn ignition key “OFF”.
- The end of the procedure is confirmed by a long low-pitched acoustic signal.

16.0 - SYSTEM RESET



By activating the following procedure, the system returns to the factory default settings. This procedure must therefore only be used in case of need, before programming the system or auto-learning the turn indicator flashes.

To reset the system proceed as follows:

- Switch-off the system power supply.
- Short-circuit the RED and BLACK wires of the 2-pin LED connector.
- Switch the system ON; once the alarm system is powered, 4 acoustic signals will sound and the turn indicators will flash 4 times.
- Remove the previously created short-circuit; the status LED lights up steady.
- Turn ignition key "ON"; reset is confirmed by an acoustic signal and the wailing of the siren for approx. 3 seconds.
- Turn ignition key "OFF"; the LED will turn OFF. There are no acoustic signals.

17.0 - TECHNICAL SPECIFICATIONS

Power supply 823 - 822	12 Vdc
Current absorption @ 12Vdc with system armed and LED flashing	15mA
Working temperature range	From -30°C to +70°C
Turn signals relay contact capacity	8 A at 20°C
Engine immobiliser relay contact capacity	8 A at 20°C
Alarm cycle duration	30 sec.
Maximum positive current output when armed (+A)	700 mA
Additional siren output current capacity	1 A



Aftermarket Vehicle Solutions Limited

7 Dudley Court , Jessop Close, Clacton-on-Sea, Essex, CO15 4LY

TEL: +44 (0) 1255 434353

Email: sales@avsgemini.com | Web: www.avsgemini.com

UK Distributors of the Gemini Alarm Systems

AVS reserve the right to effect changes to the product without further notice. E&OE